

The graphic features the letters 'ERG' in a bold, orange, sans-serif font. The letters are set against a circular, glowing effect that resembles a lens flare or a sunburst. This circular element is positioned on the left side of a horizontal banner. The banner itself has a dark blue background with a subtle, light-colored grid pattern. A thin, bright yellow horizontal line runs across the banner, passing behind the 'ERG' text. Below the banner, there are several horizontal white lines that fade out to the right, creating a sense of motion or depth.

ERG

Toward an ERG Position on Next Generation Access Networks

Cara Schwarz-Schilling, PT NGN

Turin, 17 April 2007

Draft Consultation Document on regulatory principles for NGA

- Main findings on NGA: Results of Country Case Studies
- FTTCab and FTTH/FTTB Scenario
- Economics of NGA
- Regulatory Implications
 - Market 11
 - Market 12
 - FTTCab Wholesale Access Products
 - FTTH/FTTB Wholesale Access Products
- Ladder of Investment in an NGA environment

Main findings on NGA

- To date, limited knowledge of NGA rollout plans
- In several countries incumbents plan to roll out fibre to the cabinet
- Also FTTB/H is considered,
- Country case studies show a large variety of rollout strategies across Europe
- Information on rollout strategies of incumbents is crucial for managing transition process
- **2 Scenarios considered**
 - **Fibre to the cabinet**, which consists of a hybrid solution with DSL technology and fibre going to the street cabinet and copper between the street cabinet and the end-user.
 - **Fibre to the home** which is a fully optical solution going to the end-user premises. Fibre to the building is included in this scenario even though, technically, it has to be considered a hybrid solution.

Access Architectures using Fibre

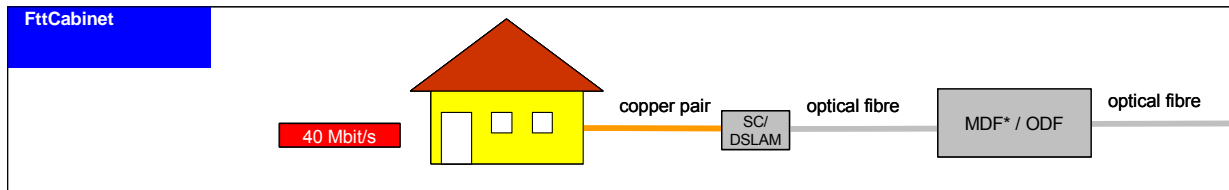
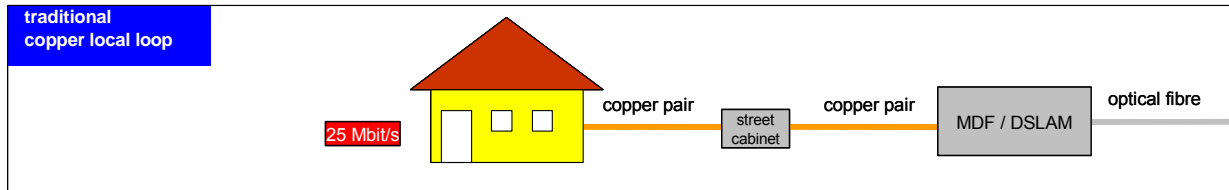

Depending on whether MDF are phased out or not

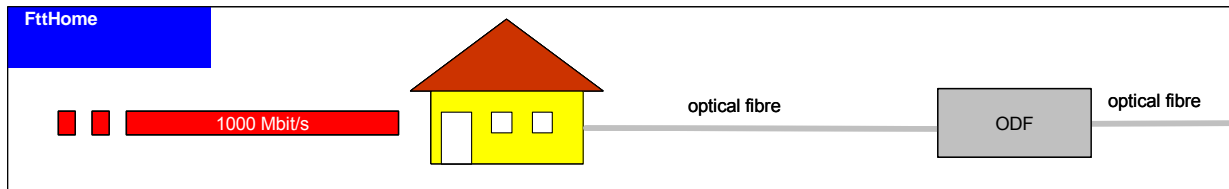
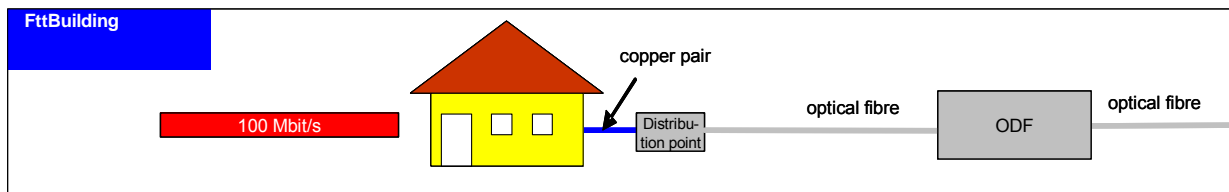

Access Architectures using Fibre

FttCabinet

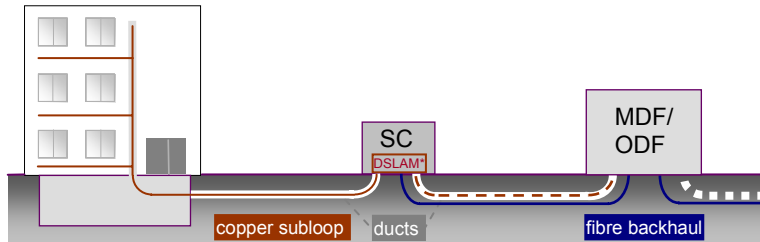

FttBuilding

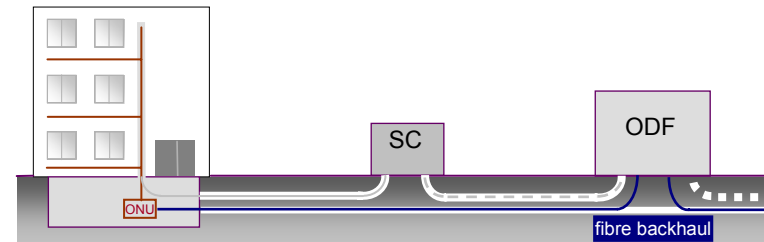

FttHome (point to point)

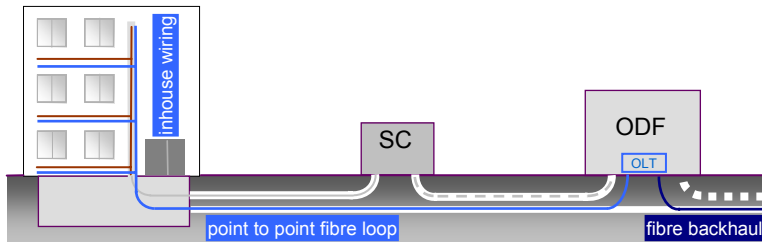

FttHome (PON)

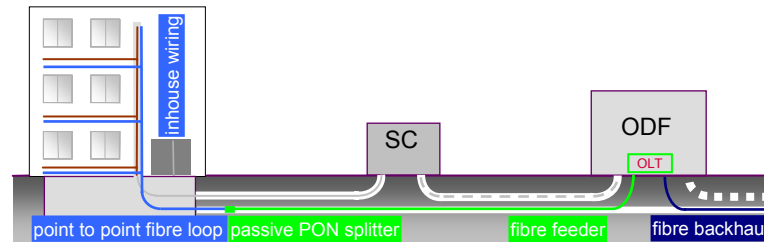

Economics of NGA

- A mixture of technologies will be used for NGA deployment depending on a number of parameters and specific local characteristics, including
 - copper local loop and sub-loop lengths,
 - customer density and dispersion,
 - the number of street cabinets per MDF.
 - Economics of NGA networks are likely to vary across different technologies and different geographies, i.e. between MS and within MS.
 - Increase in costs per line/user due to a lower No of end customers per node.
 - Viability of the business case also depends on the demand side and additional ARPU that can be attained by offering customers innovative services.
- **NGA investments are likely to reinforce the importance of scale and scope economies, thereby reducing the degree of replicability, potentially leading to an enduring economic bottleneck.**

Distribution of Subscriber Loop Length

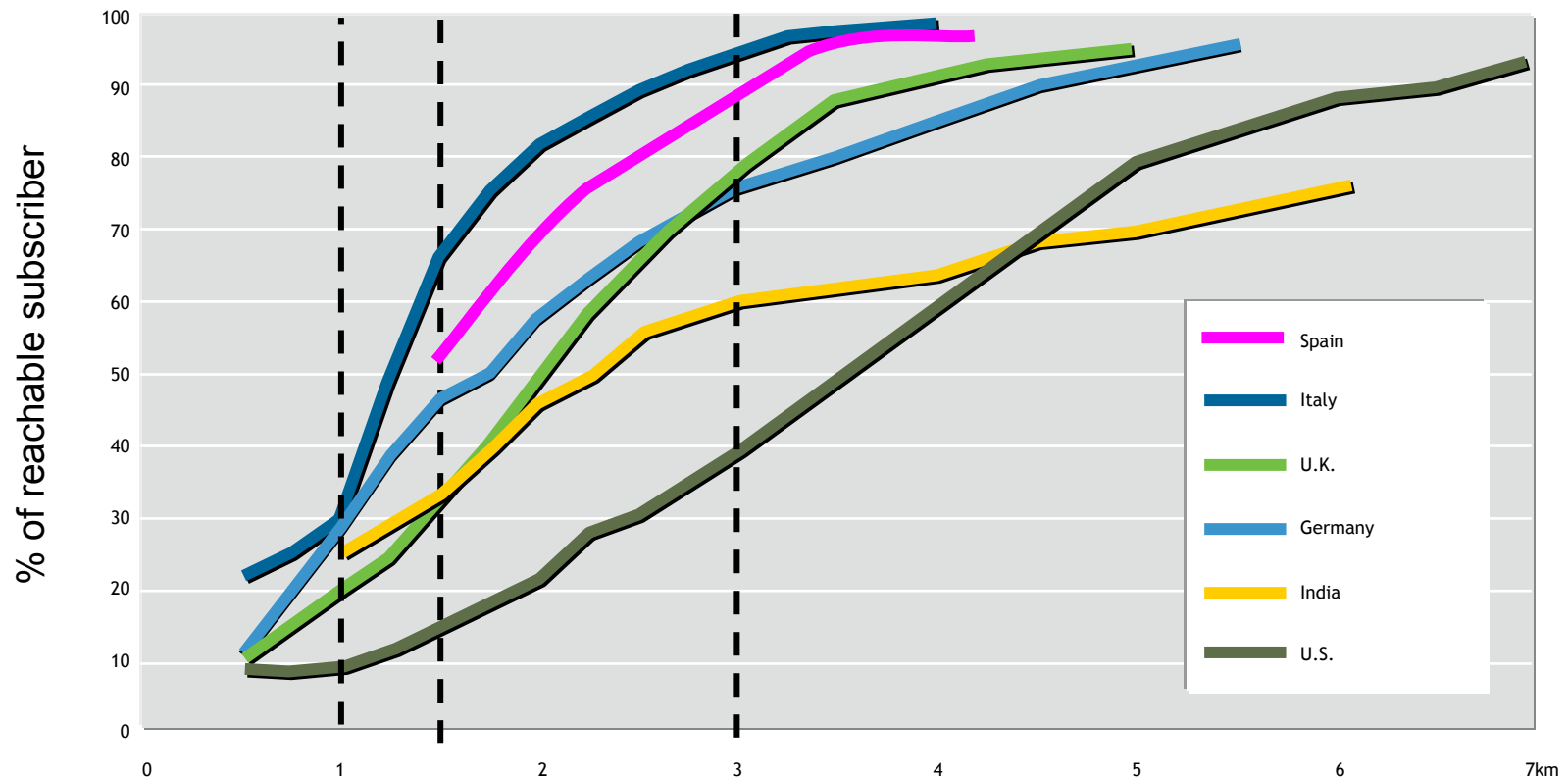

CAPEX vs. total households/density (Source: Arcep)

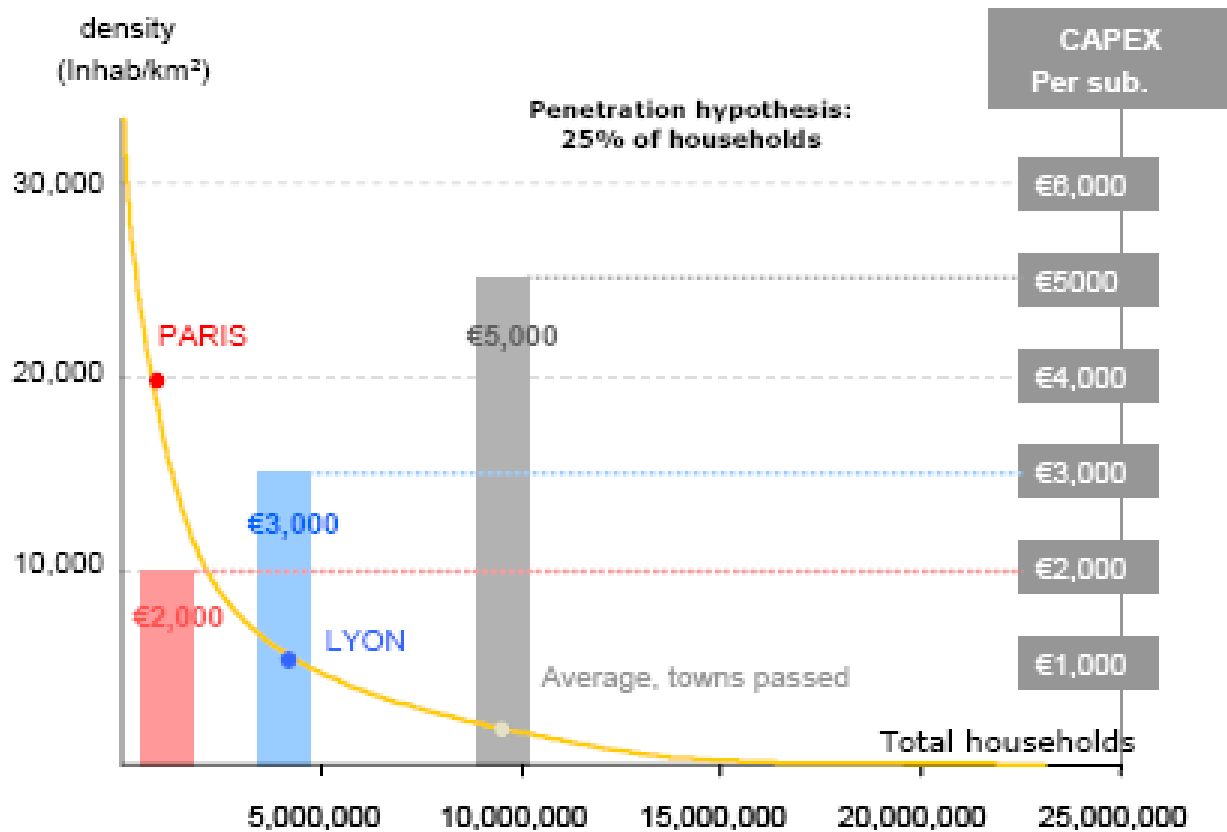

Regulatory implications 1: ULL (Market 11)

- FTTCab - the local loop consists of the copper line from the cabinet to the home;
- FTTB - the local loop consists of the copper line from the building entrance (where fibre ends) to the end-user premises;
- FTTH - the local loop would simply be constituted by optical fibre from the ODF to the end-user (home).
 - in point-to-point solutions, it may be possible to unbundle the local loop in a manner very similar to that used today for copper – full LLU of the loop is applied from the ODF;
 - in a point-to-multipoint solution (shared infrastructure topology, such as PON), it is no longer easily possible to associate a single physical element of connectivity with a particular end-user.

Regulatory implications 2: WBA (Market 12)

- Bitstream access at MDF may become more important.
- Market 12, as defined in the Recommendation already comprises all kinds of wholesale broadband access products. Therefore no change is required.
- Bitstream products might need to be enhanced for maximum control of quality parameters. Changes in the SMP-party's network may also imply changes of the WBA product that have to be adapted accordingly.
- Bitstream offers on FTTx architecture can provide the same type of services using Ethernet at the access plus backhauling to Ethernet switches at different levels or the IP level. Ethernet services allow more features such as native multicast (e.g. of TV channels).
- When carrying out a substitutability test between markets 11 and 12, a relevant factor is that bitstream access by the competitor at layers 2/3 reduces the freedom of the competitor to control quality parameters, compared to the LLU case, where the authorized operator gets access to the physical line (layer 1 access).

Examples of the 'local loop' under different technology deployments

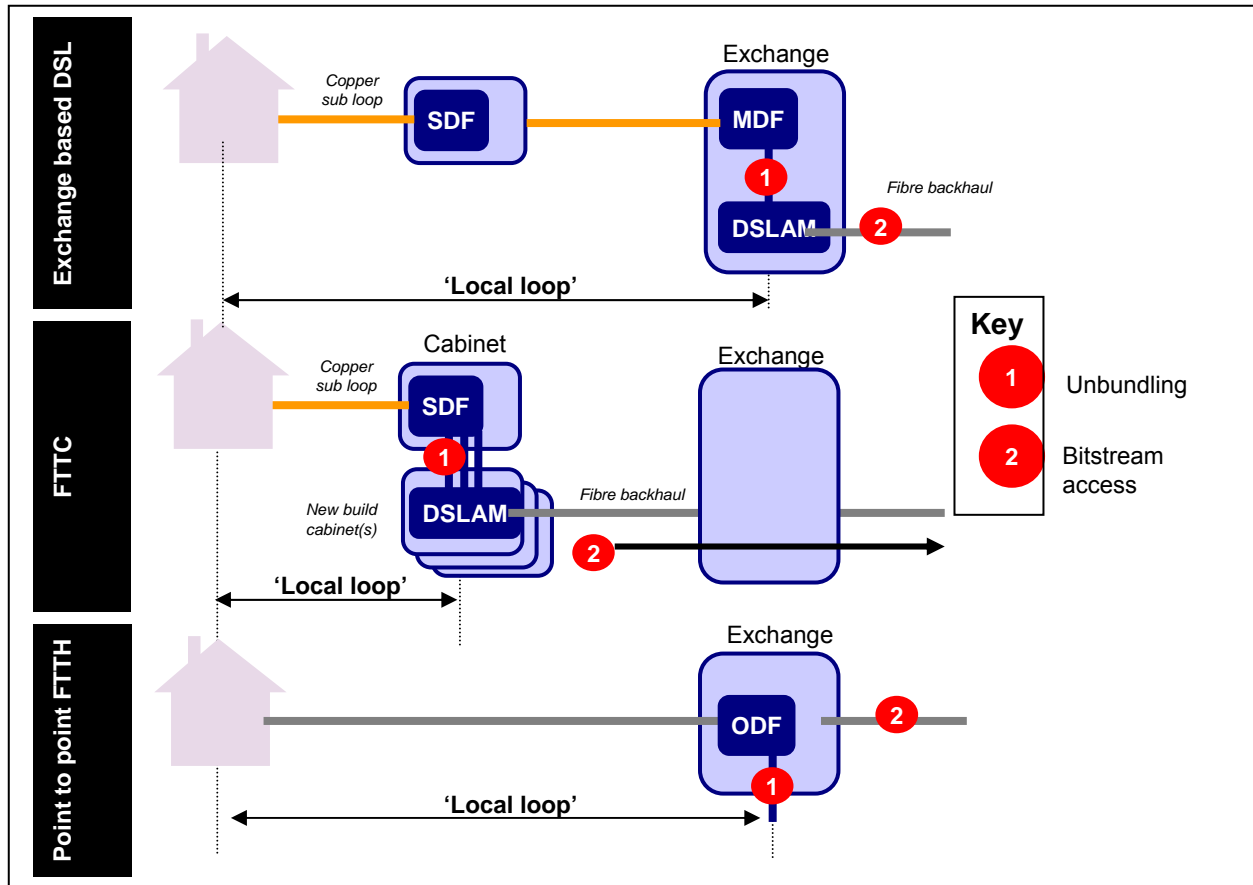

Regulatory implications 3: FTTCab Wholesale access products

- The main barriers are
 - Colocation at the street cabinet,
 - Backhaul between the Street Cabinet and the operators' networks.
- Street cabinet unbundling may become more important:
 - Colocation at the street cabinet could be imposed as an ancillary service obligation to SLU, provided it is technically feasible
- Complementary products such as backhaul services in the middle mile from the cabinet to the operator's node and/or duct sharing may be needed:
 - Backhaul could be considered:
 - as an ancillary service to market 11;
 - as a wholesale terminating segment of leased lines (market 13);
 - or a separate backhaul market could be defined.
 - Duct sharing could be imposed as an ancillary service to market 11.

Regulatory implications 4: FTTH/FTTB Wholesale access products

- The main barriers are
 - Civil engineering cost (horizontal barrier) and
 - In-house wiring (vertical barrier)
- Fibre has to be included in market 11 in order to allow for the unbundling of the optical local loop (if SMP has been assessed in this market).
- Amendment of the Recommendation required, which is in line with the definition of the AD
- Other possible wholesale products, e.g. duct sharing
 - Under the SMP framework
 - Symmetric regulation to be imposed on all operators based on Article 12 FD could be strengthened, to ease facility sharing e.g.
 - Obligation to negotiate sharing of facilities under reasonable requests
 - Settlement procedures before NRA in case of refusal;
 - allow MS to intervene in particular for promoting fair competition,
 - NRA may impose the setting up of extra facilities.

Ladder of investment in an NGA environment

